



INSTALLATION INSTRUCTIONS



2003-2009 NISSAN 350Z 3.5L

PART NO. 19342

BILL OF MATERIALS:

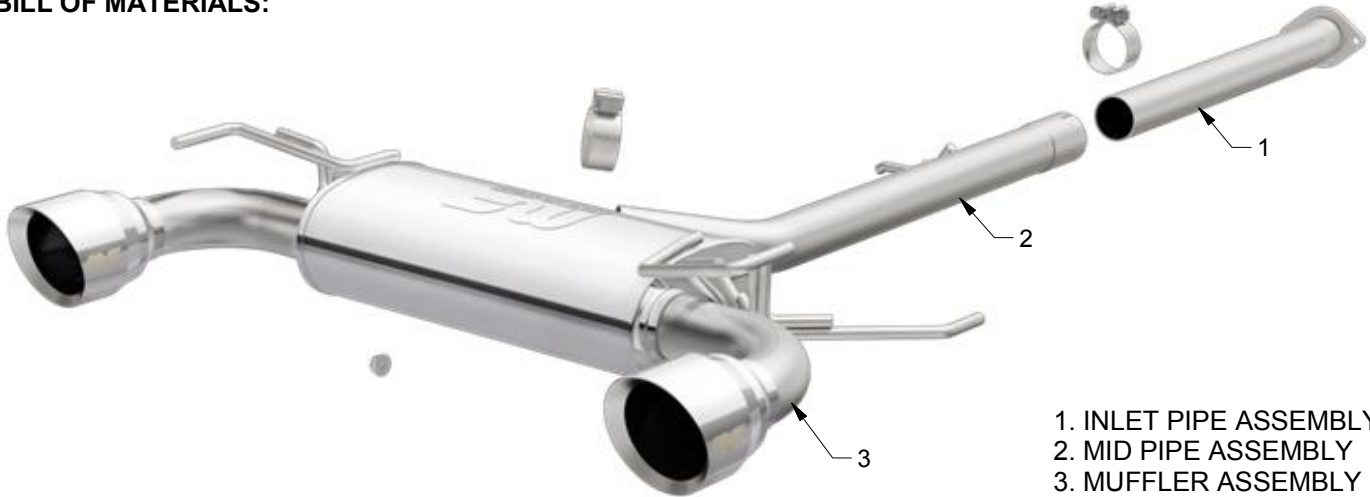

- 1. INLET PIPE ASSEMBLY
- 2. MID PIPE ASSEMBLY
- 3. MUFFLER ASSEMBLY



WEAR SAFETY GLASSES



READ INSTRUCTIONS THOROUGHLY BEFORE INSTALLING PRODUCT

SHOP SUPPLIES:



SPRAY LUBRICANT

To ease removal of existing exhaust components (especially on older vehicles) spray penetrating lubricant on all fasteners and hangers/insulators that will be loosened or removed and let soak before disassembly.

HARDWARE KIT:

- 1.[2] 2.50" Clamp

MINIMUM REQUIRED TOOLS:



13, 15mm



Hanger Tool (Or Pry Bar)

MAGNAFLOW RECOMMENDS PROFESSIONAL INSTALLATION ON ALL THEIR PRODUCTS



WARNING: When working on, under, or around any vehicle exercise caution. Please allow the vehicle's exhaust system to cool before removal, as exhaust system temperatures may cause severe burns. If working without a lift always consult vehicle manual for correct lifting specifications. Always wear safety glasses and ensure a safe work area. Serious injury or death could occur if safety measures are not followed.

ATTENTION: Always install any supplied band or U-bolt clamps to the proper torque specifications of 40-45 ft-lbs for band clamps and 30-35 ft-lbs for U-bolt clamps. Over tightening will result in the clamp breaking and will NOT be warranted by MagnaFlow.

MAGNAFLOW: 22961 Arroyo Vista - Rancho Santa Margarita, CA 92688 | 1(800) 990-0905

Technical Support: 1(800) 959-9226 | Email: moreinfo@magnaflow.com

19342 7/22/16 REV 000

INSTALLATION INSTRUCTIONS



Step 1. Begin removal of the OEM exhaust system by unbolting the flanges attaching the exhaust to the catalytic converter. Do not discard or damage the OEM fasteners or rubber insulators as they will be used to install the new system.



Step 2. Unbolt the flange junction between the mid pipe and the muffler assembly. Disengage hangers from rubber insulators and remove the OEM exhaust.



Step 3. Begin installation of your new MAGNAFLOW system by attaching the flanges of the Inlet Pipe Assembly to the catalytic converter outlet using the OEM hardware. Keep all fasteners and clamps loose until final adjustment.



Step 4. Next loosely attach the Mid Pipe Assembly to the Inlet Pipe Assembly using the supplied clamp. Engage the welded hanger to the rubber insulator.

INSTALLATION INSTRUCTIONS



Step 5. Loosely attach the Muffler Assembly to the Mid Pipe Assembly using the supplied clamp. Engage all welded hangers to the rubber insulators.



Step 6. Once a final position has been chosen for the new exhaust system, evenly tighten all clamps from front to rear using the torque specifications on page one of the instructions. Inspect all fasteners after 25-50 miles of operation and re-tighten if necessary.