

CARDONE™ ProTech®

Supporting Today's Vehicle Technician



Power Steering Pump 20-8002 Installation Tip

Application

Dodge Truck R2500, R3500, 1997-2002 with 5.9L Diesel Engine.

Problem

Due to the distinct removal and installation characteristics of the 20-8002, proper care must be used to prevent improper mounting and/or damage to the vacuum pump and its corresponding oil seal. Follow the tips below for removal and installation of this unit. Please refer to your vehicle's service manual for more detailed instructions if needed.

Removal

1. Use caution when sliding the power steering pump away from the vacuum pump - do not damage the oil seal (arrow #4) in the vacuum pump.
2. Remove the two mounting spacers (arrow #7). Do not discard; these must be re-installed.

Installation

1. Install the two mounting spacers.
2. Rotate the steering pump shaft (arrow #1) until the adapter (arrow #6) aligns with the vacuum pump drive (arrow #3). Install the steering pump onto the vacuum pump bracket. CAUTION: Use care to avoid damaging the oil seal (arrow #4) in the vacuum pump during installation. The steering pump housing and spacers (arrow #7) must mate completely with the mounting bracket (arrow #5).
3. Install the vacuum pump bracket to steering pump nuts and tighten to 18-ft. lbs.
4. Position new gasket on vacuum pump assembly. NOTE: Use sealer if necessary to retain the gasket.
5. Align and install the pump assembly on the engine. Ensure the steering pump stud is inserted into the block bracket. Tighten the pump-to-engine block attaching bolts to 57-ft. lbs.
6. Install the steering pump to the mounting bracket nut and tighten to 18-ft. lbs.
7. Install the pressure and return hoses to the power steering pump. Tighten the pressure fitting at the pump to 23-ft. lbs.

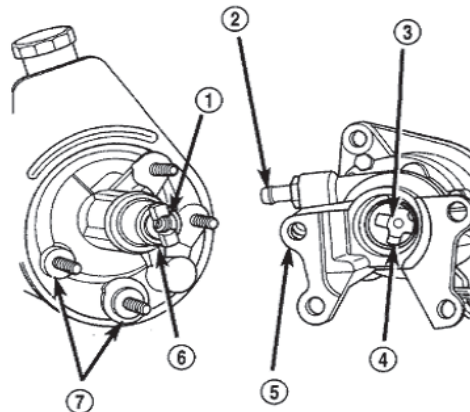

1. Power Steering Pump Shaft
2. Vacuum Fitting
3. Vacuum Pump Drive
4. Oil Seal
5. Mounting Bracket
6. Power Steering Pump Shaft Adapter
7. Mounting Spacers