

CARDONE™ ProTech®

Supporting Today's Vehicle Technician



Excessive Rotation of Steering Causes Air Bag Coil Damage

Application All vehicles equipped with steering column air bags.

Problem Steering column air bag inoperative after steering gear replacement.

Cause Excessive steering wheel rotation during installation of steering gear, resulting in a broken air bag coil.

Solution The steering wheel **must** be held in the center position prior to removal of intermediate steering shaft (use appropriate tool). This will prevent excessive rotation of the steering column and failure of the air bag coil.

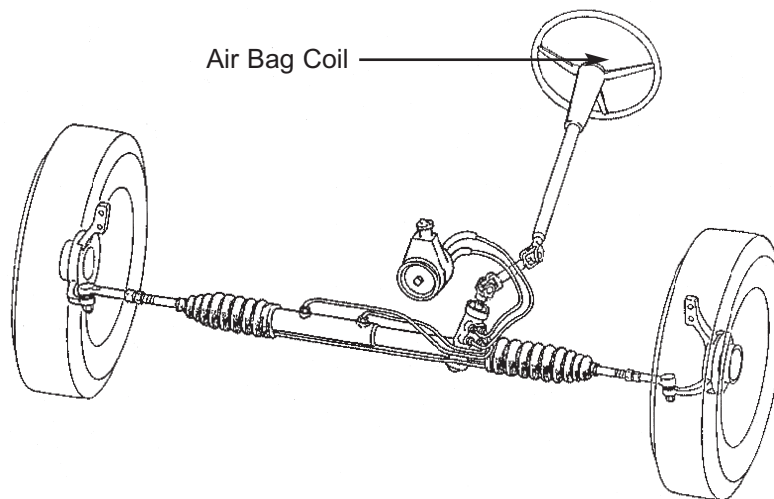

Note Consult a shop manual for more specific manufacturers' service procedures and specifications.