



TYPHOON INTAKE SYSTEMS

NOT LEGAL FOR SALE OR USE ON ANY POLLUTION CONTROLLED MOTOR VEHICLE IN CALIFORNIA OR STATES ADOPTING CALIFORNIA EMISSION PROCEDURES. See knfilters.com for CARB status on each part for a specific vehicle

INSTALLATION INSTRUCTIONS

69-1505TWR
HONDA
2017-19 Civic Type R
L4-2.0L Turbo

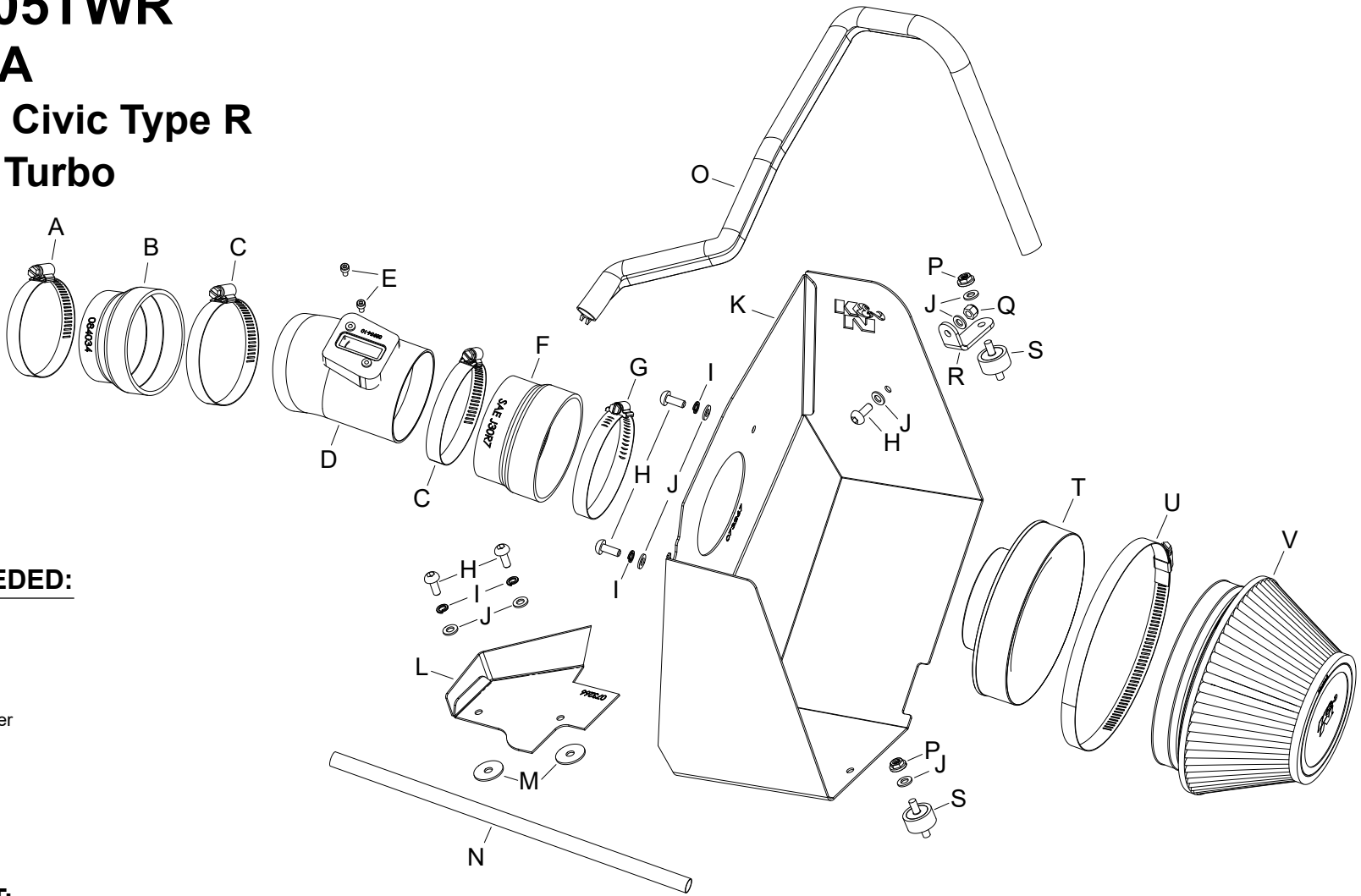

TOOLS NEEDED:

- ratchet
- extension
- 10mm socket
- 10mm wrench
- 3mm allen key
- phillips screw driver

PARTS LIST:

Description	Qty.	Part #	Description	Qty.	Part #	Description	Qty.	Part #
A HOSE CLAMP #44 STAINLESS	1	08560	H BOLT; M6 X 1.00 X 16MM, SS	5	07730	O EDGE TRIM; 3/4" BULB, TOP	1	102489
B HOSE; 3.25" TO 2.75"ID X 2"L	1	084034	I WASHER, M6 SPLIT LOCK ZINC	4	1-3025	P NUT; SERRATED M6	2	KIT20WFCZ060
C HOSE CLAMP #48	2	08601	J WASHER; 6MM FLAT, SS	8	08269	Q NUT; 6MM NYLOCK, HEXHEAD	1	07512
D TUBE; 3.25"OD X 4-1/2"L, AL	1	25808WR	K HEAT SHIELD; 69-1505, MILD	1	073267	R BRACKET; "L", 69-1505, STL	1	064356
E BOLT; M4 - 0.7 8MM, A/H CAP	2	07733	L DUCT; FRESH AIR, MILD STL	1	073266	S STUD; M6-1.00 M/M, RUBBER	2	07027
F HOSE; 3.25"ID TO 3.5"ID X 2.25"	1	084091	M WASHER; 1" X .30 X .063	2	21685	T ADAPTER; UNIVERSAL, 6"	1	21512-1
G HOSE CLAMP #52	1	08610	N HARNESS COVER; 1/2" X 13"	1	21785	U HOSE CLAMP; #104	1	08697
						V 6"FLG, 7-1/2"B, 4-1/2"T, 4"H	1	RU-4600

If you need any assistance please call 1-800-858-3333 to speak with a representative in our Customer Service Center before returning the product.

NOTE: FAILURE TO FOLLOW INSTALLATION INSTRUCTIONS AND NOT USING THE PROVIDED HARDWARE MAY DAMAGE THE INTAKE TUBE, THROTTLE BODY AND ENGINE.

TO START:

1. Turn off the ignition and disconnect the negative battery cable.
NOTE: Disconnecting the negative battery cable erases pre-programmed electronic memories. Write down all memory settings before disconnecting the negative battery cable. Some radios will require an anti-theft code to be entered after the battery is reconnected. The anti-theft code is typically supplied with your owner's manual. In the event your vehicles anti-theft code cannot be recovered, contact an authorized dealership to obtain your vehicles anti-theft code.



2. Disconnect the mass air sensor electrical connection and unhook the harness from the air filter housing.



3. Release the upper air filter housing clips and loosen the hose clamp that secures the intake hose to the turbo inlet pipe. Remove the upper air filter housing and intake tube from the vehicle.



4. Remove the four bolts that secure the lower air filter housing and fresh air scoop and then remove the complete assembly from the vehicle.
NOTE: K&N Engineering, Inc., recommends that customers do not discard factory air intake.



5. Install the two provided rubber mounted studs into the factory air filter housing mounting locations as shown.

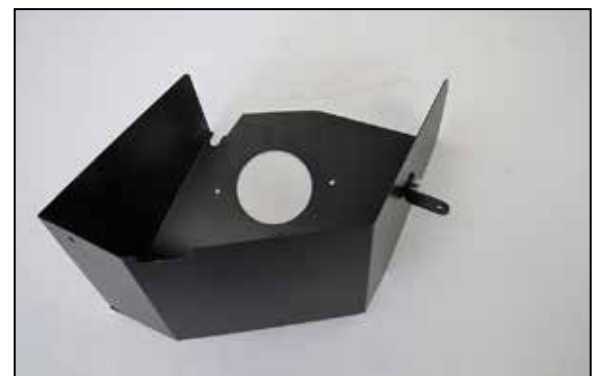

6. Install the provided mounting bracket onto the heat shield and secure with the provided hardware.

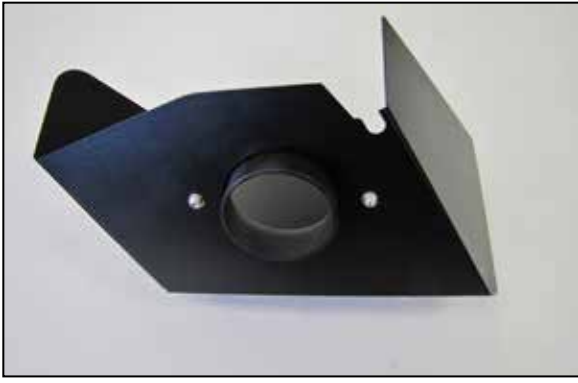

7. Install the filter adapter into the heat shield and secure with the provided hardware.



8. Install the provided edge trim onto the heat shield as shown.

NOTE: Leave the edge trim long as shown, it will be trimmed in a later step.

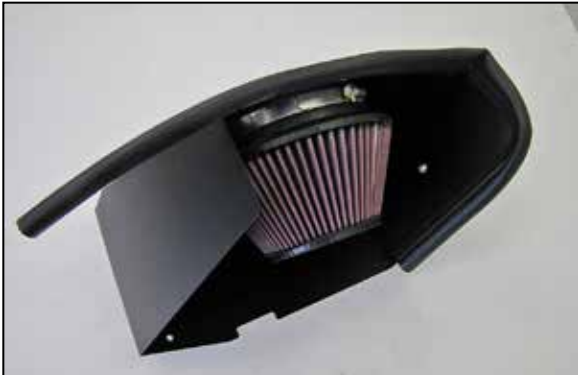

9. Install the K&N® air filter onto the filter adapter and secure with the provided hose clamp.



10. Set the heat shield assembly into position on the rubber mounted studs and then secure with the provided hardware.



11. Remove the mass air sensor from the factory housing and install it into the K&N® intake tube as shown.



12. Install the provided coupler (084091) onto the inlet side of the K&N® intake tube and secure with the provided hose clamp.



13. Install the provided coupler (084034) onto the outlet side of the K&N® intake tube and secure with the provided hose clamp.



14. Install the intake tube assembly onto the turbo inlet and filter adapter, adjust the tube for best fit and secure with the provided hose clamp.

NOTE: Be sure the tube is in the correct direction, the opening in the mass air sensor should be towards the air filter.



15. Remove the plastic harness holder from the mass air sensor harness. Install the provided split harness cover and secure with electrical tape. Route the harness through the notch in the front of the heat shield and then reconnect the mass air sensor electrical connection.



16. Install the provided fresh air duct and secure with the provided hardware. Install the remaining length of edge trim onto the fresh air duct.



17. Reconnect the vehicle's negative battery cable. Double check to make sure everything is tight and properly positioned before starting the vehicle.

18. It will be necessary for all K&N® high flow intake systems to be checked periodically for realignment, clearance and tightening of all connections. Failure to follow the above instructions or proper maintenance may void warranty.

ROAD TESTING:

1. Start the engine with the transmission in neutral or park, and the parking brake engaged. Listen for air leaks or odd noises. For air leaks secure hoses and connections. For odd noises, find cause and repair before proceeding. This kit will function identically to the factory system except for being louder and much more responsive.

2. Test drive the vehicle. Listen for odd noises or rattles and fix as necessary.

3. If road test is fine, you can now enjoy the added power and performance from your kit.

4. K&N Engineering, Inc., requires cleaning the intake system's air filter element every 100,000 miles. When used in dusty or off-road environments, our filters will require cleaning more often. We recommend that you visually inspect your filter once every 25,000 miles to determine if the screen is still visible. When the screen is no longer visible some place on the filter element, it is time to clean it. To clean and re-oil, purchase our filter Recharger® service kit, part number 99-5050 or 99-5000 and follow the easy instructions.

NOT LEGAL FOR SALE OR USE ON ANY POLLUTION CONTROLLED MOTOR VEHICLE IN CALIFORNIA OR STATES ADOPTING CALIFORNIA EMISSION PROCEDURES.

See knfilters.com for CARB status on each part for a specific vehicle