



40 Huntingwood Drive Huntingwood NSW 2148

Phone: (02) 8825 1999 Website: www.aeroflowperformance.com

AEROFLOW PERFORMANCE LOW PRESSURE INLINE FUEL PUMP

WARNING!

THIS PRODUCT REQUIRES DETAILED KNOWLEDGE OF AUTOMOTIVE SYSTEMS. WE RECOMMEND THAT THIS INSTALLATION BE CARRIED OUT BY A QUALIFIED AUTOMOTIVE TECHNICIAN.

INTRODUCTION

Congratulations on your purchase of the Aeroflow Performance inline fuel pump. Aeroflow Performance products cannot and will not be responsible for any damage, or other conditions resulting from misapplication of the parts described herein. However, it is our intention to provide the best possible products for our customer, products that perform properly and satisfy your expectations. Should you have any questions? Please call technical support at +61 2 8825 1900 and have the product part number on hand when calling.

These low-pressure fuel pumps from Aeroflow Performance are self-priming and generate good suction lift which makes them great for carburettors systems and a lift pump to fill a surge tank. Their small size makes them great for fitting to tight locations. They are compatible with standard diesel, ethanol and unleaded fuel systems. Featuring solid state reliability with no electrical contacts or bearings or diaphragms to wear out or fatigue over time. With the added external metal body, you can be sure that this fuel pump will stand the test of time.

Available in either a super low pressure of 1.5-4 PSI with 25GPH flow rating (AF49-1067) or low pressure of 4-7 PSI with 35GPH flow rating (AF49-1068).

Each fuel pump includes an installation kit which contains the following;

1. Fuel Pump
2. 1 x Fuel Filter (1/8" NPT male fitting to 5/16" (7.95mm) Barb)
3. 2 x Brass 1/8" NPT male to 5/16" (7.95mm) Barb
4. 2 x M6 x 1.00mm (UHL 20mm) Mounting Bolts
5. 2 x M6 Nuts

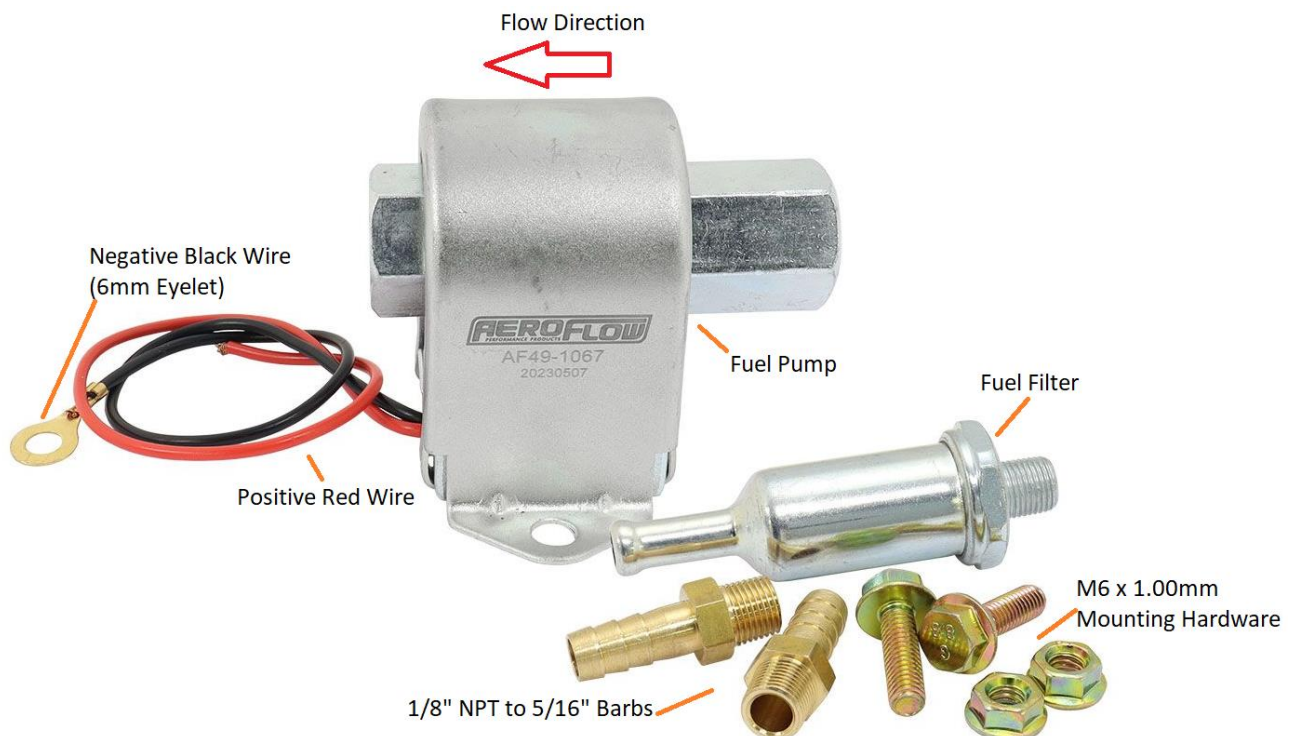

This fuel pump is alcohol and ethanol compatible. It is recommended if installing this product with these fuels that all other components are also rated to handle this type of fuel. Ensure the fuel lines are correct size for the application and are designed to handle the fuel being used. Also recommended due to the alcohol fuels breaking down rubber hoses and absorbing water, too more frequently monitor, maintain and service all fuel components including fuel filters.

The factory fuel pump wiring may not be sufficient to handle the current draw of this fuel pump. Please update all wiring if necessary and add in a relay to ensure pump works correctly. If using the existing electrical plugs and wiring in vehicle ensure correct polarity is used on the new pump.

This fuel pump is only one component of your vehicles complete fuel system. Please ensure the vehicles complete fuel system is up to the task of supplying the right amount of fuel to your engine. Failure to do so may result in severe engine damage and damage to other related components.

This universal inline fuel pump should be mounted as close to the fuel tank as possible. Do not mount the fuel pump near exhaust system or extreme heat sources as this can damage the fuel pump. Ensure the fuel pump is mounted away from any sources of water. Do not mount the fuel pump more than 12" (300mm) above the bottom level of the fuel tank. It is recommended that the outlet of the pump be at least 45 Degrees above horizontal. This will allow any vapor buildup to easily pass through the pump.

Failure to follow any of the above may result in fuel leakage, bursting of fuel lines, poor vehicle performance and/or decreased fuel pump life.

Installation Guideline

Always diagnose the cause of failure before replacing any electric fuel pump

Ensure fuel tank, fuel lines and fuel filters are cleaned from debris such as dirt and dust as this may cause the pump to fail.

1. Disconnect ground cable from battery.
2. Remove the old fuel pump from the vehicle. Ensure when removing the fuel pump no fuel spills occur.
3. Using the pump mounting bracket as a template, mark the two holes for the mounting bolts.
4. Dimple the metal with a center punch.
5. Drill two 6.5mm holes through the steel where you will be mounting the fuel pump.
6. Thoroughly clean the frame surface around the drilled holes to remove any paint, grease, rust, to ensure a good electrical connection through the frame.
 - I. THE PUMP MUST BE WELL GROUNDED OR IT WILL NOT OPERATE
7. Firmly secure the pump to the frame with nut-serts in M6. If you choose to mount the pump to a bulkhead where you have access to both ends of the mounting bolts, we suggest you use the supplied M6 bolts and nuts to secure the fuel pump.
 - I. We recommend to mount this fuel pump at 45-degree angle.
8. Install the supplied hose barb in the outlet port on the pump.
 - I. Ensure to use an appropriate thread sealer (AeroSeal) on the 1/8" NPT thread.
 - II. Ensure to use a 22mm spanner to hold the fuel pump when tightening the brass fitting.
9. Install the supplied fuel filter in the inlet port on the pump.
 - I. Ensure to use an appropriate thread sealer (AeroSeal) on the 1/8" NPT thread.
 - II. Ensure to use a 22mm spanner to hold the fuel pump when tightening the brass fitting.
10. Connect the 5/16" (8mm) fuel line from the tank to the inlet port (fuel filter) on the pump. Connect the fuel line that runs to the carburettor to the hose connected to the outlet port on the pump. Use suitable sized hose clamps to secure the ends of the hose.
11. Follow the electrical guidelines section to wire this fuel pump up
12. Reconnect the battery cable once all wired up correctly.
13. Turn ignition switch on and start engine. Check for sound of pump running or put hand on pump to feel it running if you can't hear it. Check for any fuel leaks. If leaks occur, turn off ignition switch and fix leaks. Clean up any spilled fuel. Turn ignition switch on again, start engine and recheck that pump operates and no fuel is leaking.

Electrical Guideline

1. It is suggested that this inline fuel pump be powered through a 3 to 5 Amp automotive-type fuse. If the fuel pump power circuit in your vehicle is not fused, you can insert an inline fuse holder with a 3 to 5 Amp fuse in the wire. (sold separately AF49-1507)
2. Negative ground is the black wire with the 1/4" (6mm) ring connector should be grounded to the frame. You can use one of the fuel pump mounting bolts if that bolt makes a good ground connection.
3. The Positive power is the red wire should be connected to a power source that has 12 volts when the key is in the run position. The red wire should be stripped and a 1/4" ring connector crimped on.

Mounting Position

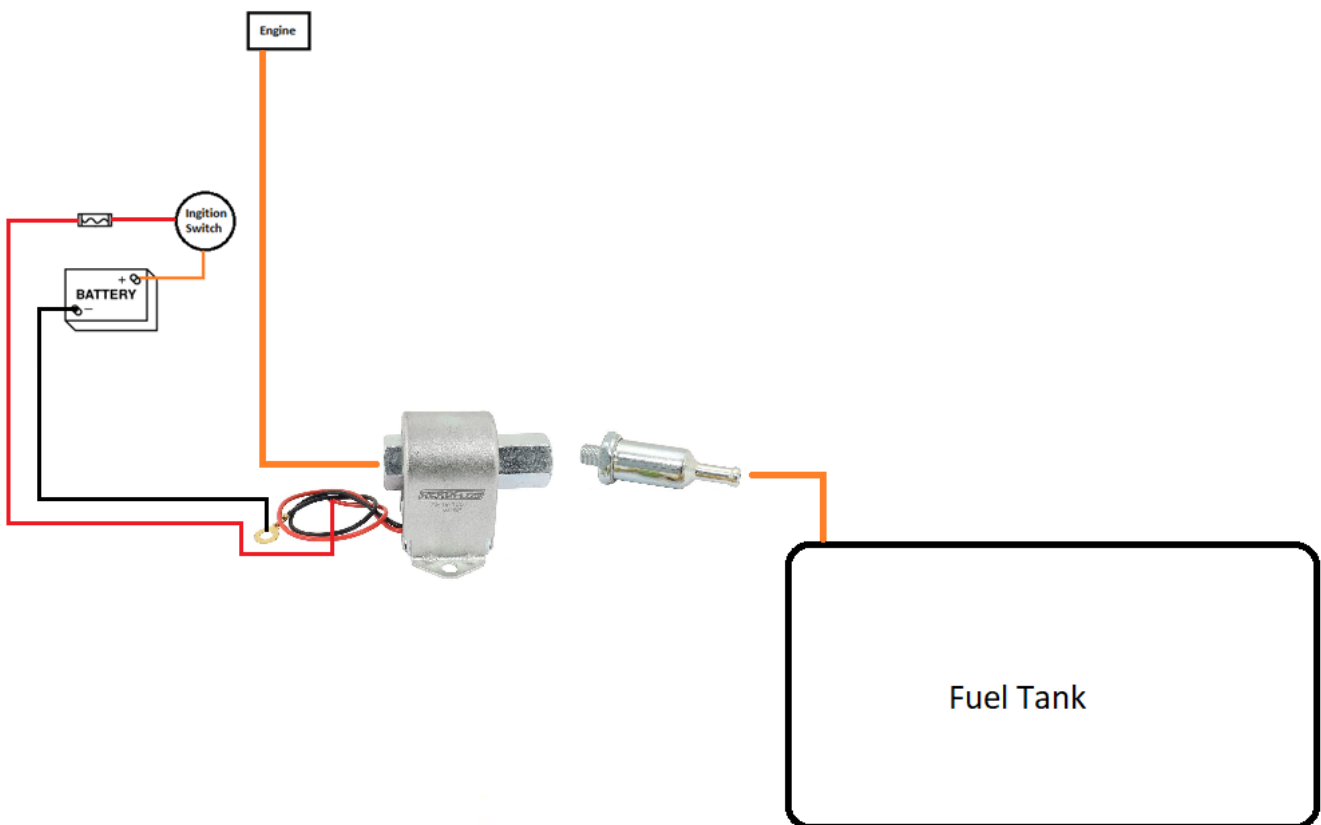
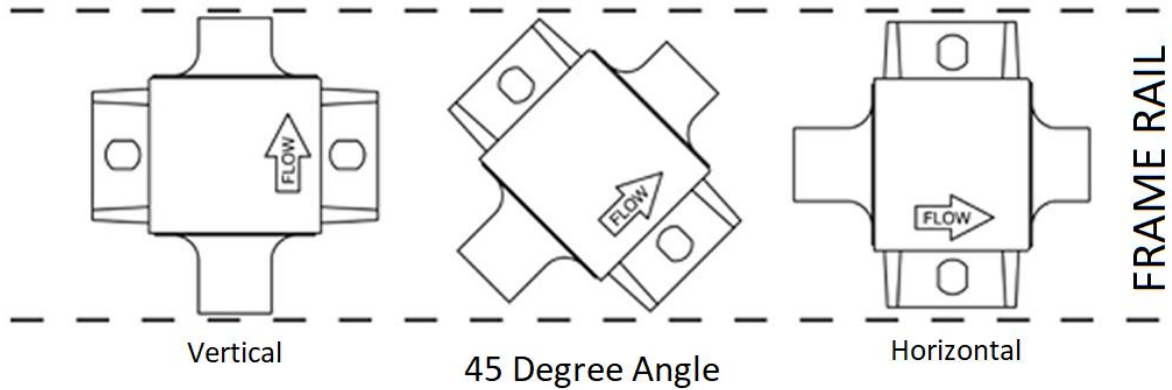

For more information or technical enquires

Contact: Aeroflow Performance on

Phone: (02) 8825 1979 Website: www.aeroflowperformance.com